

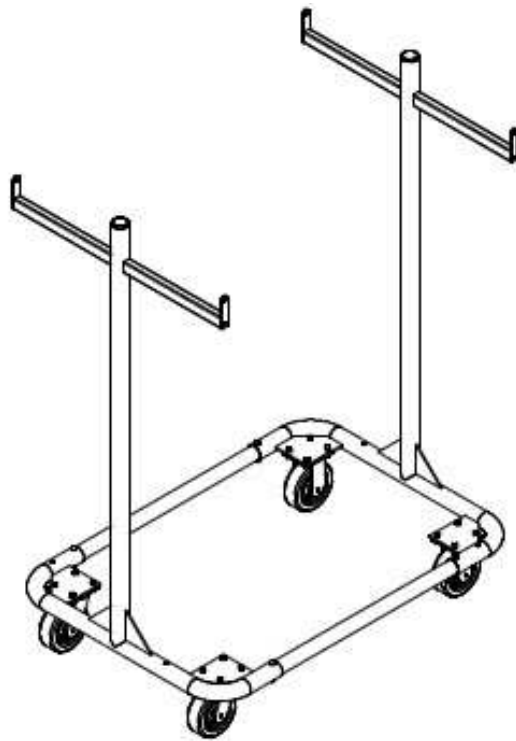

STAGERIGHT

Product Information Packet

Product Name: Guardrail/Chair Stop Carts



(Part # 322109)

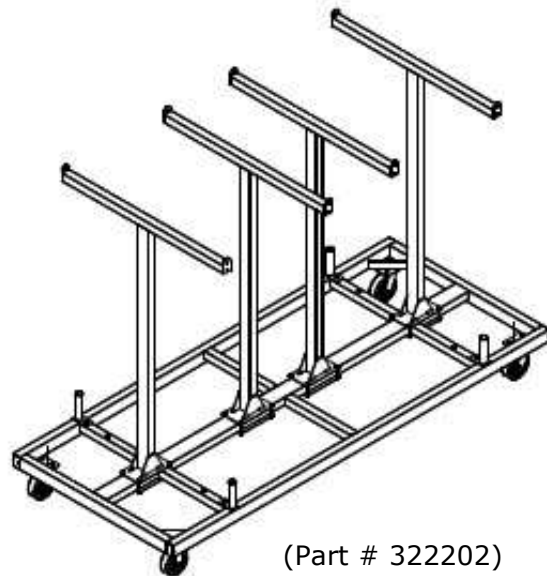

(Part # 322202)

KEEP INFORMATION PACKET FOR FUTURE REFERENCE

Table of Contents

- Introduction..... 1
- General Safety Rules..... 2
- Symbols..... 3
- 14 Rail Cart Technical Specifications..... 4
- 14 Rail Cart Assembly Instructions..... 5
- 14 Rail Cart Loading Instructions..... 7
- Guardrail/Chair stop Technical Specifications.....8
- Guardrail/Chair stop Cart Assembly Instructions..... 9
- Guardrail/Chair stop Loading Instructions.....11
- Maintenance..... 13
- Customer Service Information..... 14

Introduction

The Guardrail Cart has been designed and manufactured with safety, performance and dependability as top priorities, making it easy to operate and maintain.

The care you give your Guardrail Cart will greatly determine your satisfaction with its performance and service life. Careful study of this manual is encouraged to obtain a thorough understanding of your new Guardrail Cart and its functions and maintenance.

If your manual becomes lost or destroyed, StageRight will gladly provide you with a new copy. Should you require additional information or assistance, please feel free to contact us at 1-800-438-4499.

BECAUSE STAGERIGHT CORPORATION MAINTAINS AN ONGOING PROGRAM OF PRODUCT DEVELOPMENT AND IMPROVEMENT, WE RESERVE THE RIGHT TO MAKE IMPROVEMENTS IN DESIGN OR CHANGES IN SPECIFICATIONS WITHOUT INCURRING ANY OBLIGATIONS TO INSTALL THEM ON UNITS PREVIOUSLY SOLD.

General Safety Rules



WARNING!



READ AND UNDERSTAND ALL INSTRUCTIONS.

Failure to follow all instructions listed below may result in serious personal injury.

SAVE THESE INSTRUCTIONS

- **Stay clear of all pinch points.**
- **Make sure that all fasteners are properly engaged before use.** Faspins and jam nuts need to be properly engaged before use.
- **Save these instructions.** Refer to them frequently and use them to instruct others who may use the Guardrail Cart.
- **Read the Product Information Packet.** Failure to read the information packet is considered a misuse of this equipment.
- **Become familiar with all caution and warning decals affixed to the staging equipment before use.**
- **Never cover or deface caution/warning labels.**
- **Transport carts are designed to carry only STAGERIGHT manufactured guardrails and chair stops.**

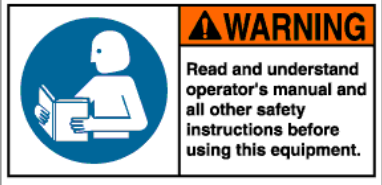
Symbols

	<p>Safety Alert: Precautions that involve your safety</p>
	<p>Read The Operator's Manual: To reduce risk of injury, user must read and understand operator's manual before using this product</p>
	<p>Pinch Point Warning Label: Failure to keep hands away from pinch points will result in personal injury</p>

StageRight Corporation Technical Specifications

Guardrail Cart

Part #	Description	Weight	Load Capacity
322109	Guardrail Cart	65 lbs	14 Guardrails

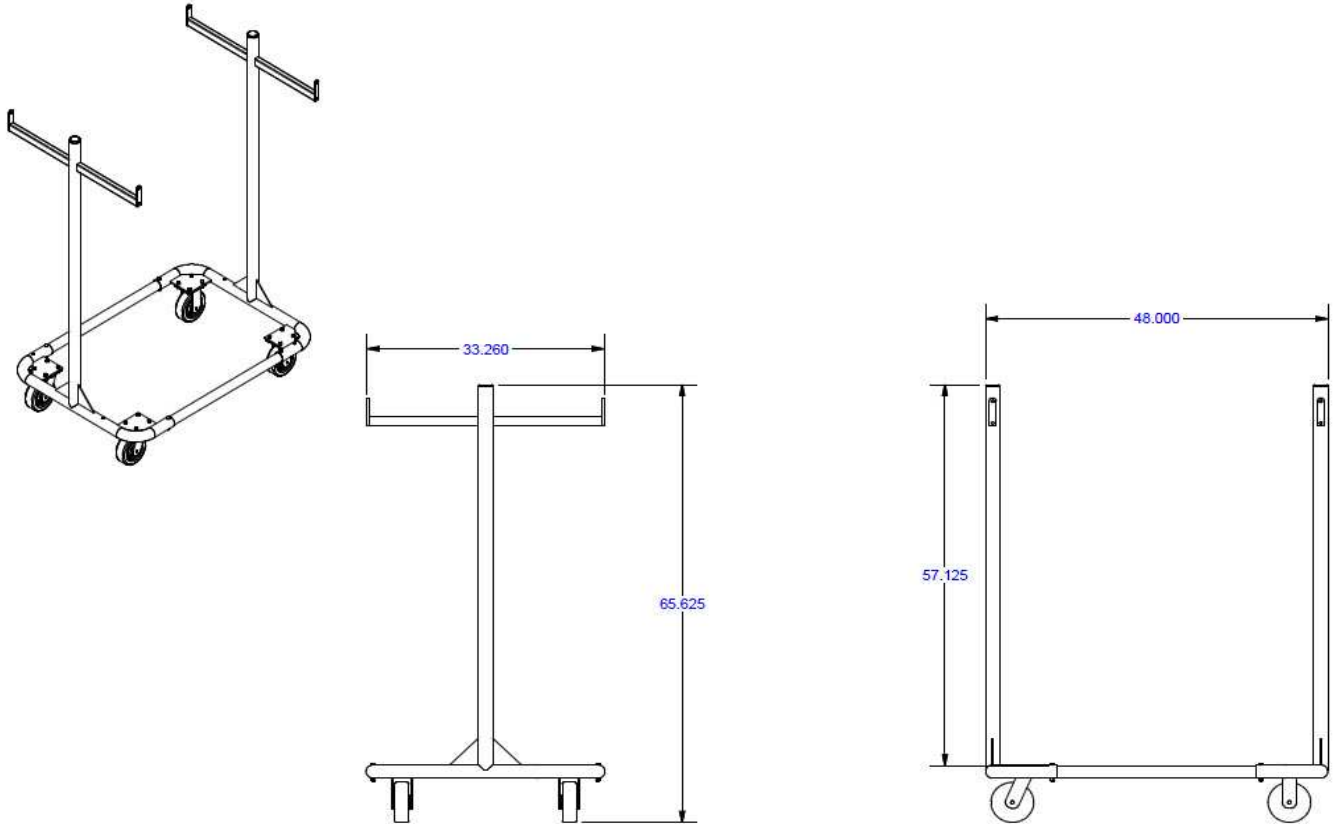

Construction, Finish, and Hardware

- Constructed of ASTM specified steel
- Baked-on powder coat finish.
- Zinc-plated hardware

Assembly Instructions

Note: Two people recommended for assembly.

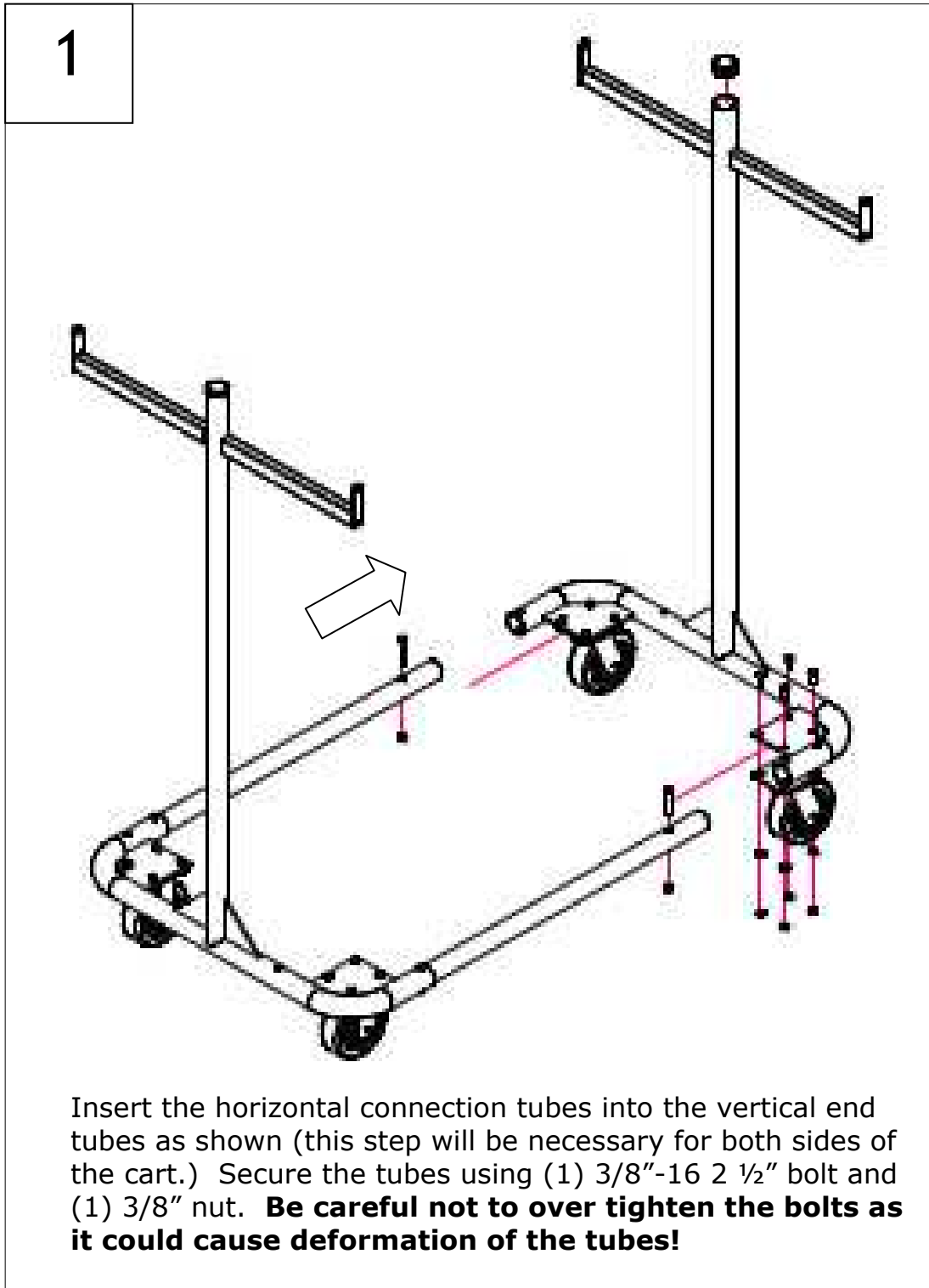

2

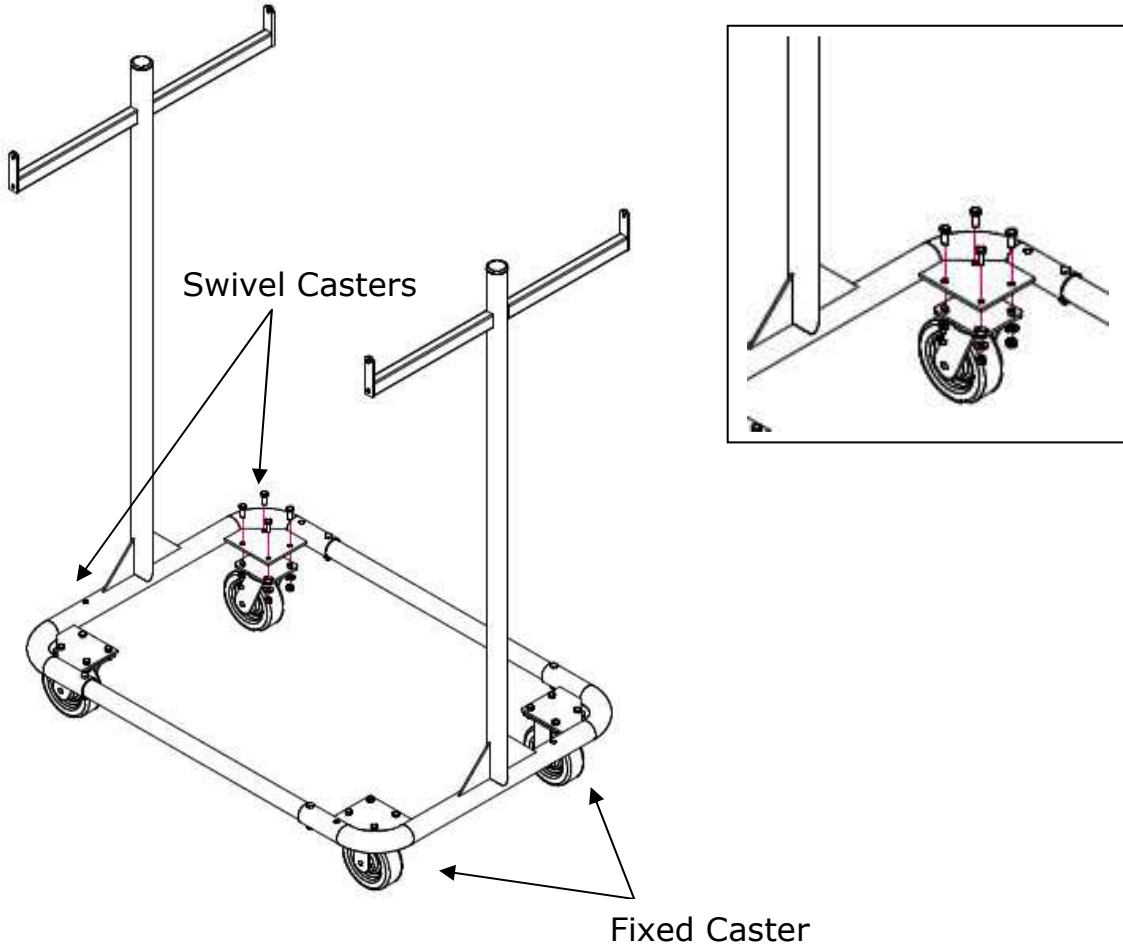

Attach the (4) casters to the frame tubes as shown using (4) 3/8-26 1" bolts (4) 3/8" washers and (4) 3/8"-16 nuts. **Note:** There are (2) swivel casters and (2) fixed casters, be sure to match the caster types on each end for proper functionality. **Be sure to tighten the bolts completely!** Repeat for each caster.

Loading Instructions

1

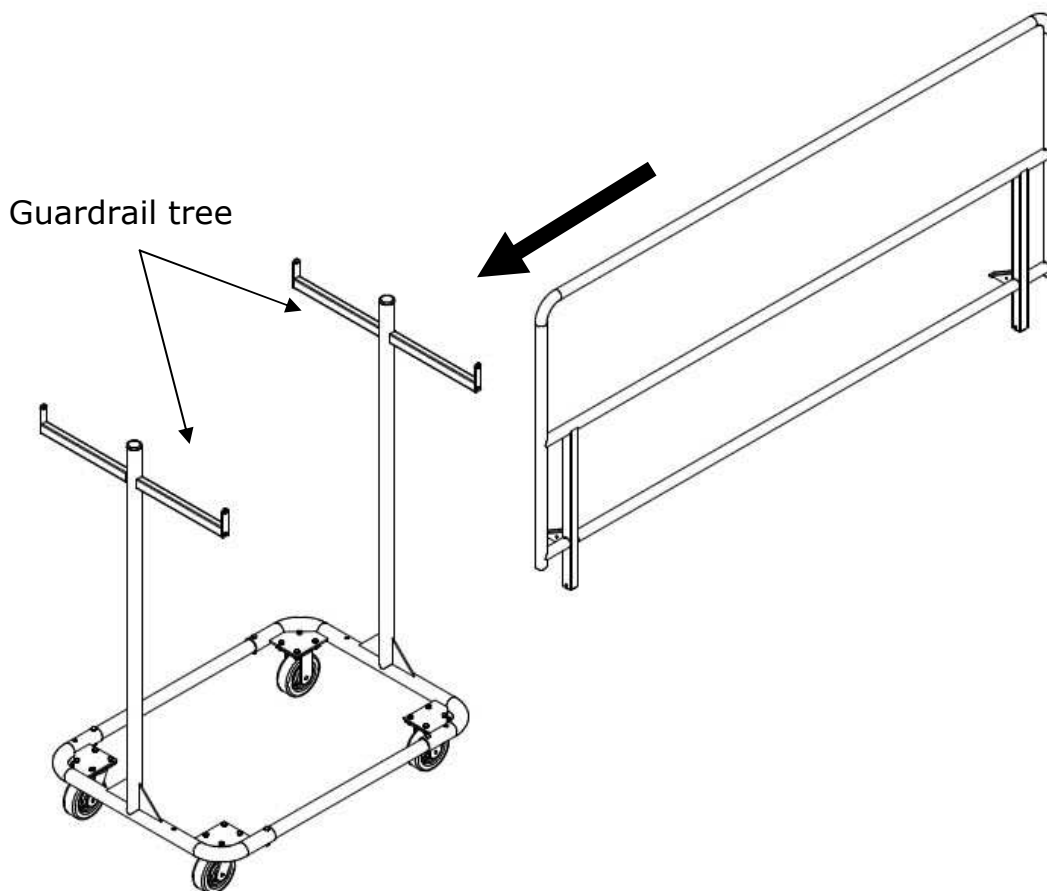

Place guardrails on the transport cart as shown. Center the guardrail on the transport cart so that the guardrail's weight is evenly distributed on the tree posts. The Transport Cart is rated to handle 14 guardrails total, 7 on each side. Be sure to load the cart evenly, alternating guardrail placement to avoid tipping the cart over.

StageRight Product Specifications

Guardrail/Chair-stop cart

Part #	Description	Weight
322202	GRDL/CHSTP	334 lbs

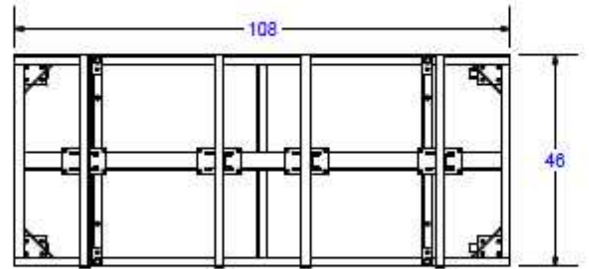
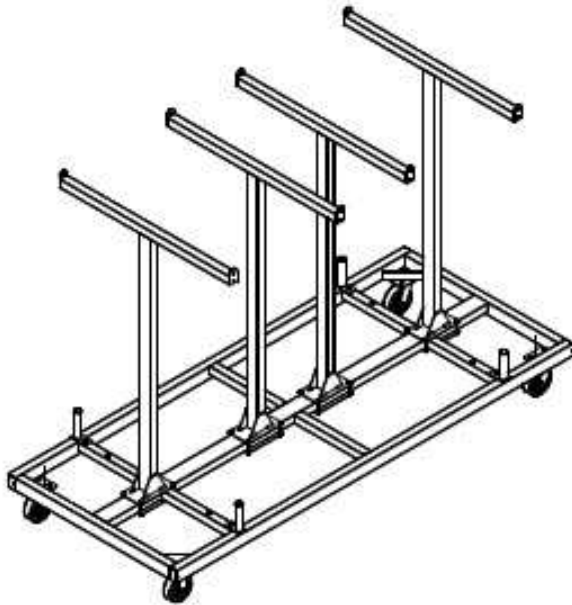

Loading Capacity		
Length	Guardrail	Chair Stop
4ft	52	90
6ft	26	45
8ft	26	45

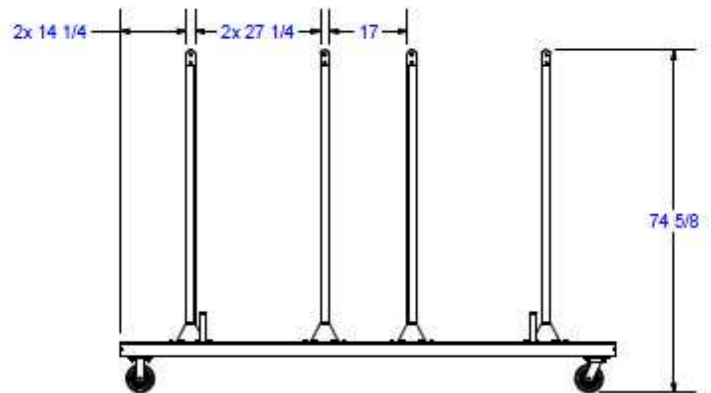

Construction, Finish, and Hardware

- Constructed of ASTM specified steel
- Baked-on powder coat finish.
- Zinc-plated hardware

Assembly Instructions

Note: For your safety, Assembly Will Require Two People

1

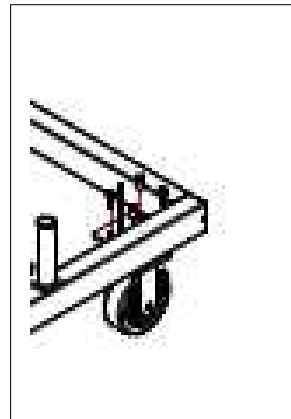
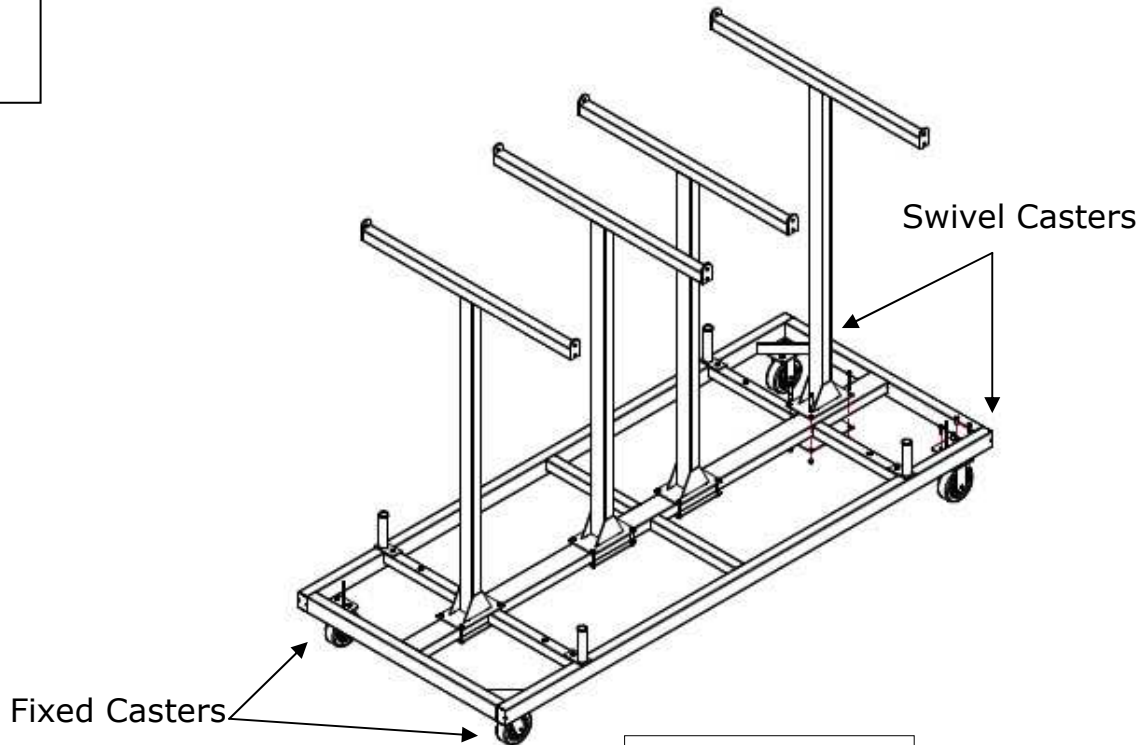

With a helper, attach the (4) casters to the frame tubes as shown using (4) 3/8-26 1" bolts (4) 3/8" washers and (4) 3/8"-16 nuts. **Note:** There are (2) swivel casters and (2) fixed casters, be sure to match the caster types on each end for proper functionality. **Be sure to tighten the bolts completely!**

2

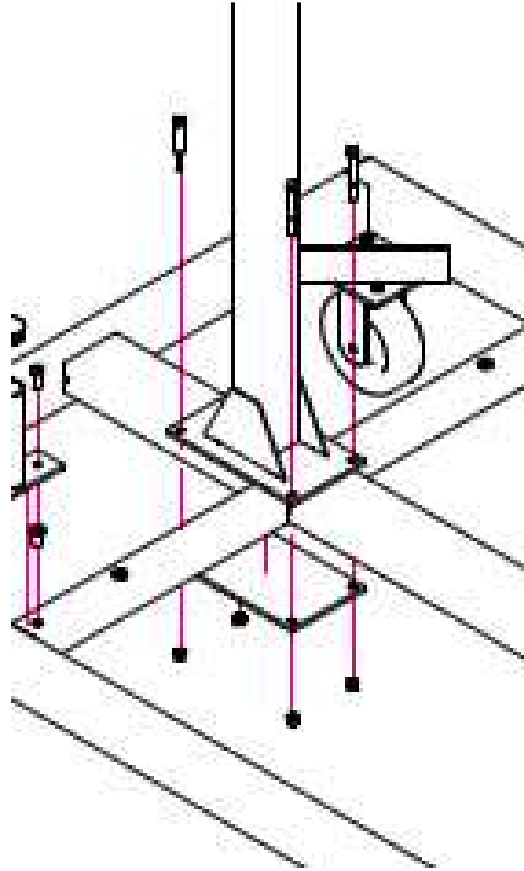

Caution! Chock casters before performing the next step!

With a helper, attach the horizontal tree uprights using (4) 3/8"-16 3" bolts and (4) 3/8-16 nuts and the bottom upright plate to secure the uprights to the cart base. Finger tighten the bolts until all (4) have been located, completely tighten the bolts using a cross pattern to ensure the plate is seated flush with the base surface.

Be mindful of the pinch points created by the plates contacting the base surface. Repeat for all tree uprights.

Loading Instructions

1

Guardrails

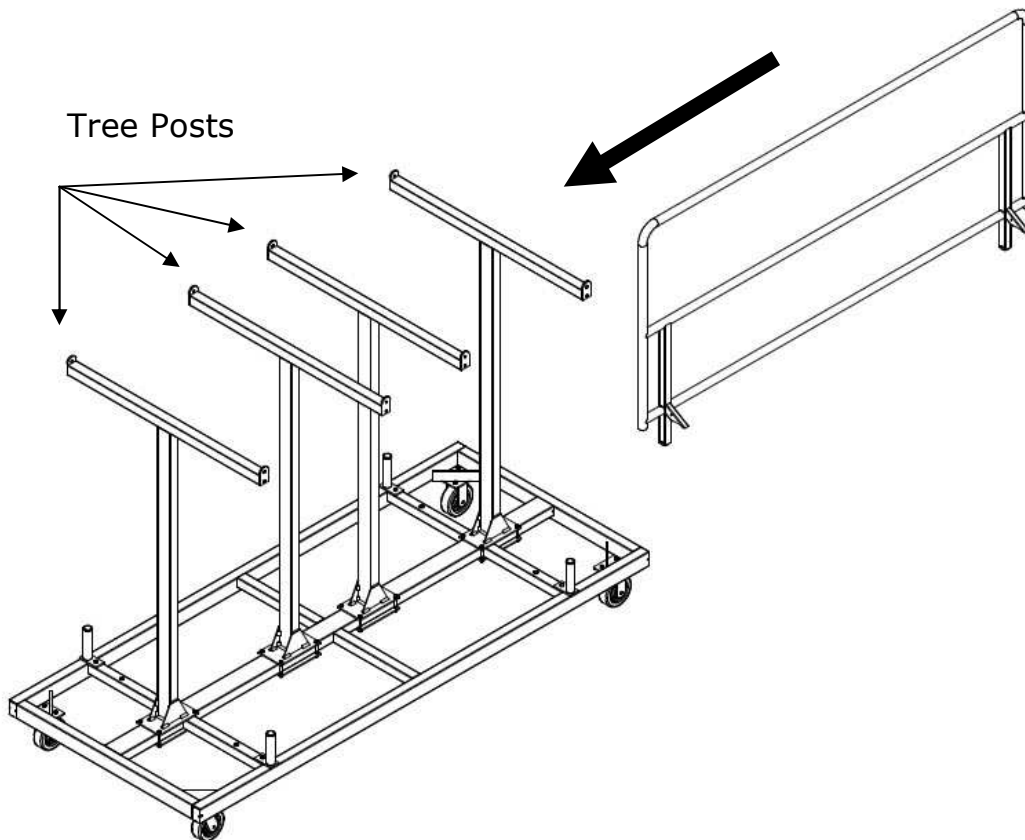

Place guardrails on the support cart as shown. Center the guardrails on the support cart so that the guardrails' weight is evenly distributed on the tree posts. Be sure to load the cart evenly, alternating guardrail placement to avoid tipping the cart over. **See chart on Pg. 8 for maximum loading conditions!**

2

Chair Stops

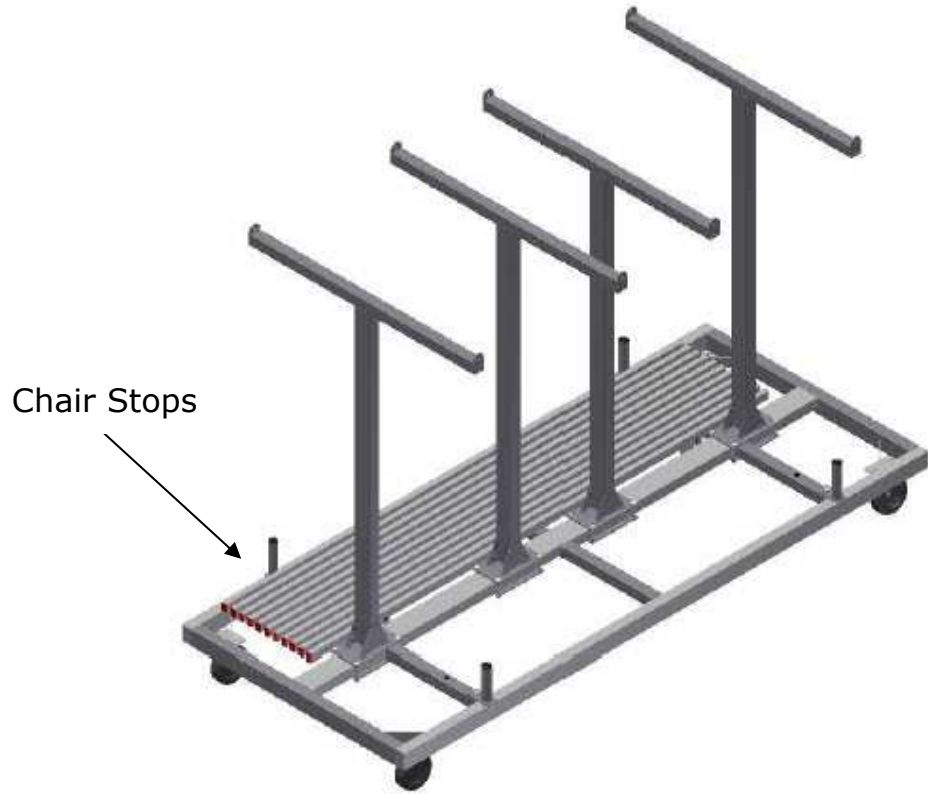

Load chair stops on the bottom of the transport cart as shown. The maximum chair-stop loading capacities are shown in the table in Pg.8

Maintenance



WARNING!

Read and Understand All Maintenance Procedures

Failure to follow all procedures listed below may cause serious injury and a decrease in the equipments functional existence.

- **Frequently check to see that all fasteners are properly engaged.**
- **Touch up paint can be used to cover any scratches or blemishes sustained through use.**
- **Replace any damaged equipment with genuine StageRight parts.** Failure to do so may result in unsafe equipment and/or personal injury.

Customer Service

For parts or service contact StageRight Corporation. When ordering parts be sure to provide all relevant information available including the name and part number of the equipment purchased. This information is located on the technical specification page of this product information package. Customer Service hours are Monday thru Friday from 8:00 a.m. to 5:00 p.m. Eastern Standard Time. Customers can phone toll-free at (800) 438-4499 or mail:

StageRight Corporation
495 Pioneer Parkway
Clare, Michigan 48617
www.stageright.com



SET UP IN MINUTES



STURDY, WITH NO TOOLS REQUIRED



UNSURPASSED CUSTOMER SERVICE

StageRight Corporation
495 Pioneer Parkway
Clare, MI 48617
Toll-free: 800-438-4499
Phone: 989-386-7393
Email: info@stageright.com
Web: www.stageright.com